

Spare Parts

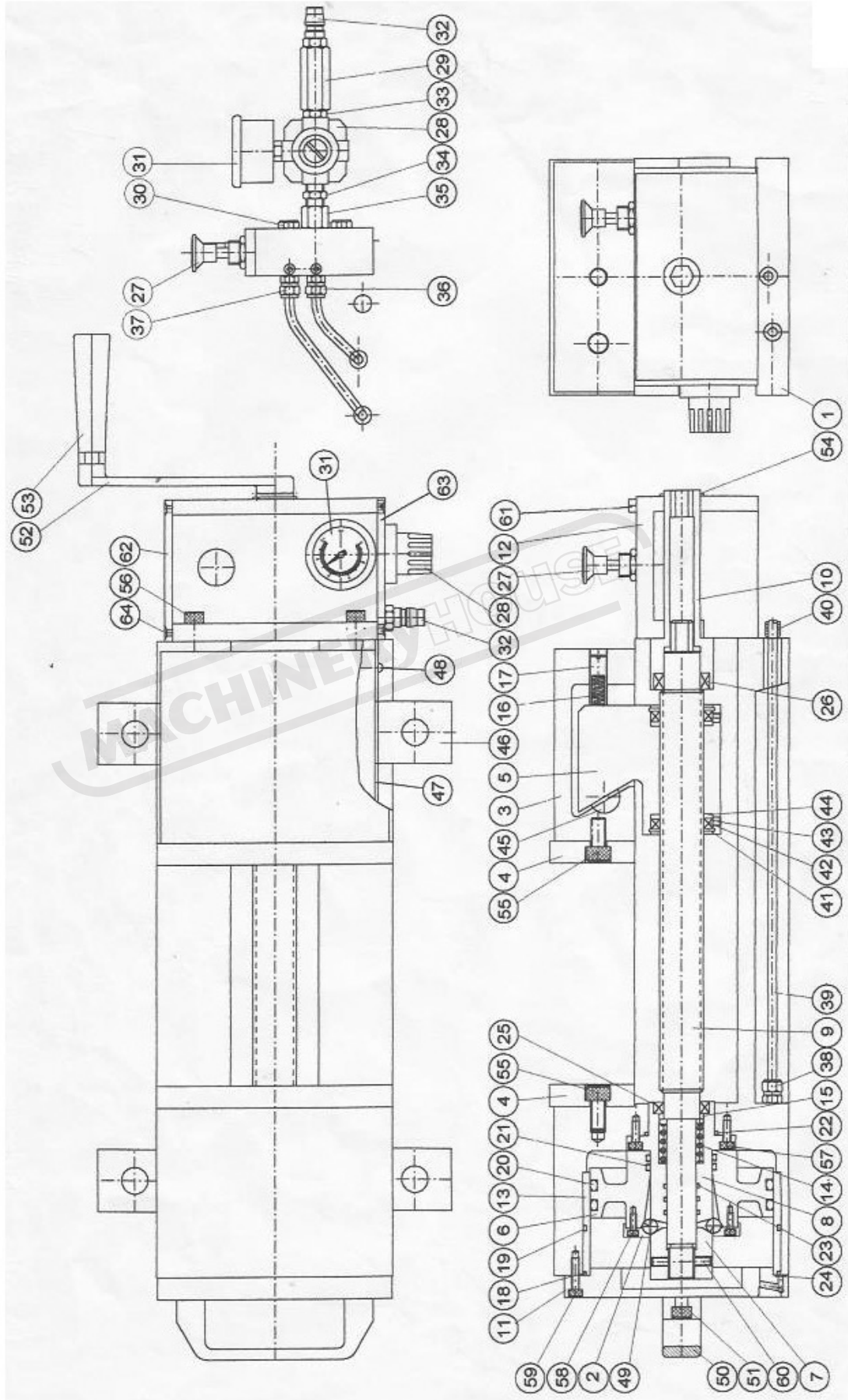

DATE:27 July. 2005
Computer No:07700200

NO.	Computer No.	Part No.	Part Name	Q'ty	Specification		Remark
1	07700200-001	PQV-200-001	Main Body	1			
2	07700160-002	PQV-160-002	Steel Ball Cover	1			
3	07120200-003	CHV-200-003	Movable	1			
4	07120200-004	CHV-200-004	Jaw Plates	2			
5	07120200-005	CHV-200-005	Lock-Down Body	1			
6	07700200-003	PQV-200-003	Generate Power Piston	1			
7	07700160-004	PQV-160-004	Generate Power Taper	1			
8	07700200-005	PQV-200-005	Generate Power Holder	1			
9	07700200-006	PQV-200-006	Main Screw	1			
10	07700160-017	PQV-160-017	Main Screw Holder	1			
11	07700200-008	PQV-200-008	Cover	1			
12	07700200-018	PQV-200-018	Main Screw Support	1			
13	07700200-010	PQV-200-010	Piston Sleeve	1			
14	07700160-011	PQV-160-011	Spring	1			
15	07700160-012	PQV-160-012	Washer	1			
16	07120160-021	CHV-160-021	Spring	1			
17	07120160-022	CHV-160-022	Adjusting Screw	1			
18	OR-G-160	OR-G-160	O-Ring	1	G-160		
19	OR-G-160	OR-G-160	O-Ring	1	G-160		
20	OR-P-145	OR-P-145	O-Ring	2	P-145		
21	OR-P-42	OR-P-42	O-Ring	2	P-42		
22	OR-P-45	OR-P-45	O-Ring	1	P-45		
23	OR-P-20	OR-P-20	O-Ring	3	P-20		
24	OR-P-04	OR-P-04	O-Ring	1	P-04		
25	OS382508	OS382508	Oil-Seal	1	38x25x08		
26	OS382508	OS382508	Oil-Seal	1	38x25x08		
27	Mod. 358-910	Mod. 358-910	Operated Valves	1	358-910 camozzi		
28	M008-R00	M008-R00	Pressure Regulator	1	M008-R00 camozzi		
29	VNR-843-06	VNR-843-06	Unidirectional Valve	1	VNR-843-06		
30	SEP-1/8"	SEP-1/8"	Silencer	2	1/8"		
31	LED-1-1/2"x1/8"	LED-1-1/2"x1/8"	Pressure Gauge	1	10kg		
32	ZCPM-1/4"PT	ZCPM-1/4"PT	Tube Nipple	1	1/4"		
33	BCN-0202	BCN-0202	Connector	1	1/4"x1/4"		
34	BCN-0202	BCN-0202	Connector	1	1/4"x1/4"		
35	BFM-0201	BFM-0201	Nipple	1	1/4"x1/8"		
36	BCB-6M01	BCB-6M01	Tube Nipple	1	6mmx1/8"		
37	BCB-6M01	BCB-6M01	Tube Nipple	1	6mmx1/8"		
38	BCB-6M01	BCB-6M01	Tube Nipple	2	6mmx1/8"		
39	PU-TUBE-6x4	PU-TUBE-6x4	Air Tube	2	6x4mm		
40	SPRING	SPRING	Spring for chip	2			
41	SR-R-47	SR-R-47	Snap Ring	2	R-47		
42	07120200-020	CHV-200-020	Chip Seal	2			
43	SSM06X08L	SSM06X08L	Set Screw	2	M6x8L		

DATE:27 July. 2005
Computer No:07700200

Computer No.	Part No.	Part Name	Q'ty	Specification		Remark
WS6204	WS6204	Spring Washer	4	6204		
07800200-006	PHV-200-006	Semi-Sphere Segment	1			
07120160-025	CHV-160-025	Vise Clamp Block	4			
07700200-013	PQV-200-013	Name Plate(V)	2	PQV-200V		
07700200-013-1	PQV-200-013-1	Name Plate(S)	2	PQV-200S		
SDM04X08L	SDM04X08L	Round Socket Cap Screw	8	M4x8L		
SB10	SB10	Steel Ball	10	10mm		
M.443-CH-37101	M.443-CH-37101	Handle Grip	1			
SCM08x16L	SCM08x16L	Socket Cap Screw	2	M8x16L		
08100160-049	08100160-049	Handle	1			
GR-001	GR-001	Handle Grip	1	10mm		
SR-S-25	SR-S-25	Snap Ring	1	S-25		
SCM12X25L	SCM12x25L	Socket Cap Screw	4	M12x25L		
SCM10X25L	SCM10x25L	Socket Cap Screw	2	M10x25L		
SCM05X16L	SCM05x16L	Socket Cap Screw	4	M5x16L		
SCM05X10L	SCM05x10L	Socket Cap Screw	4	M5x10L		
SCM05X20L	SCM05x20L	Socket Cap Screw	8	M5x20L		
SSM06X10L	SSM06X10L	Set Screw	2	M6x10L		
SCM05X12L	SCM05x12L	Socket Cap Screw	1	M5x12L		
07700160-019	PQV-160-019	Right Cover	1			
07700160-020	PQV-160-020	Left Cover	1			
SFM04X08L	SFM04X08L	Flat Head Cap Screw	6	M4x8L		
07120200-032	CHV-200-032	Carton	1	CHV-200V		